

**1****TYPE**

- Type **A**: with pull ring, without rest position.
- Type **C**: with pull ring, with rest position.
- Type **E**: with pull lever, with stop position.

**2****3****Guide**

Steel precision casting:

zinc-plated, blue passivated **ZB**

zinc-plated and coated in epoxy resin:

black, RAL 9005, matte finish **SW**

**4****5****Plunger pin / Pull ring**

Zinc-plated steel, blue passivated

**6****Lever**

Steel precision casting:

zinc-plated, blue passivated

**7****Spring**

AISI 316Ti stainless Steel

**8****Grub screw**

Steel, zinc-plated

FEATURES AND APPLICATIONS

In the GN 722.5 spring indexing plungers the plunger pin is actuated by the pull ring or lever. This operation is performed manually, with a cable or by means of a pulling hook in the versions with pull ring. The dimensional tolerances between the tip and the guide body are chosen in order to guarantee functional reliability even in applications of approximate dimensions or in the event of contamination. The hexagonal mounting holes allow the use of socket cap screws and hexagon screws or nuts.

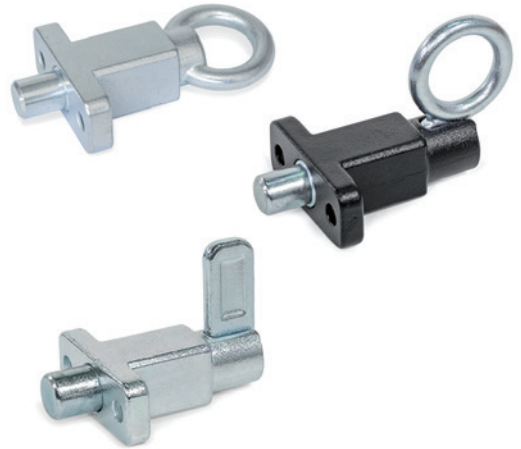
**9****10****11****12****13****14****15****16****17****18****19**

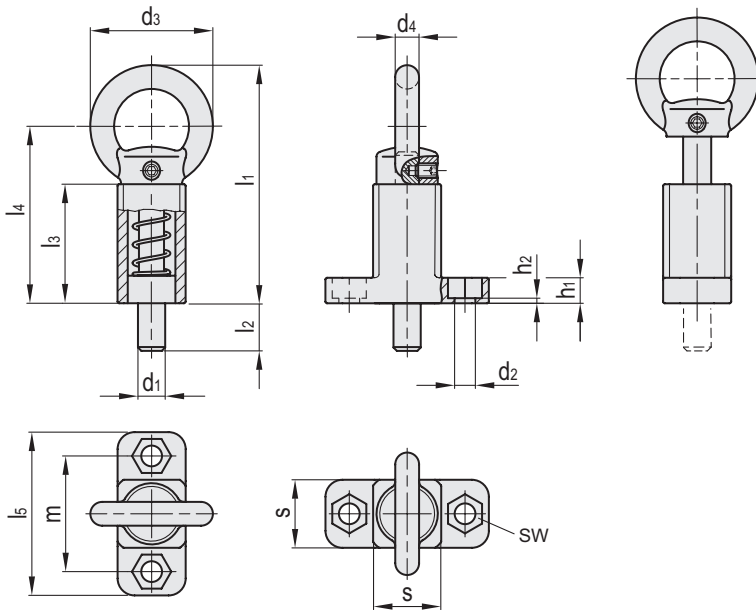

GN 722.5-A-ZB

Code	Description	d1 Plunger -0.05 -0.25 Hole +0.1 +0.3	d2 +0.3	d3	d4	h1	h2	l1	l2	l3	l4	l5	s	sw	m	Spring preload [N]	Spring max load [N]	⚖
GN.29013	GN 722.5-8-20-A-ZB	8	6.1	36	7	7.5	1.5	70	14	35	52	48	20	10	34	14	35	156
GN.29016	GN 722.5-10-20-A-ZB	10	6.1	36	7	7.5	1.5	70	14	35	52	48	20	10	34	14	35	163
GN.29019	GN 722.5-12-20-A-ZB	12	6.1	36	7	7.5	1.5	70	14	35	52	48	20	10	34	14	35	163
GN.29022	GN 722.5-14-20-A-ZB	14	6.1	36	7	7.5	1.5	70	14	35	52	48	20	10	34	14	35	167
GN.29025	GN 722.5-16-30-A-ZB	16	10.1	50	10	15	5	103	20	54	78	80	30	17	55	22	70	703
GN.29028	GN 722.5-20-30-A-ZB	20	10.1	50	10	15	5	103	20	54	78	80	30	17	55	22	70	721

GN 722.5-A-SW

Code	Description	d1 Plunger -0.05 -0.25 Hole +0.1 +0.3	d2 +0.3	d3	d4	h1	h2	l1	l2	l3	l4	l5	s	sw	m	Spring preload [N]	Spring max load [N]	⚖
GN.29012	GN 722.5-8-20-A-SW	8	6.1	36	7	7.5	1.5	70	14	35	52	48	20	10	34	14	35	156
GN.29015	GN 722.5-10-20-A-SW	10	6.1	36	7	7.5	1.5	70	14	35	52	48	20	10	34	14	35	163
GN.29018	GN 722.5-12-20-A-SW	12	6.1	36	7	7.5	1.5	70	14	35	52	48	20	10	34	14	35	163
GN.29021	GN 722.5-14-20-A-SW	14	6.1	36	7	7.5	1.5	70	14	35	52	48	20	10	34	14	35	167
GN.29024	GN 722.5-16-30-A-SW	16	10.1	50	10	15	5	103	20	54	78	80	30	17	55	22	70	703
GN.29027	GN 722.5-20-30-A-SW	20	10.1	50	10	15	5	103	20	54	78	80	30	17	55	22	70	721



- 1
- 2
- 3
- 4
- 5
- 6
- 7
- 8
- 9
- 10
- 11
- 12
- 13
- 14
- 15
- 16
- 17
- 18
- 19

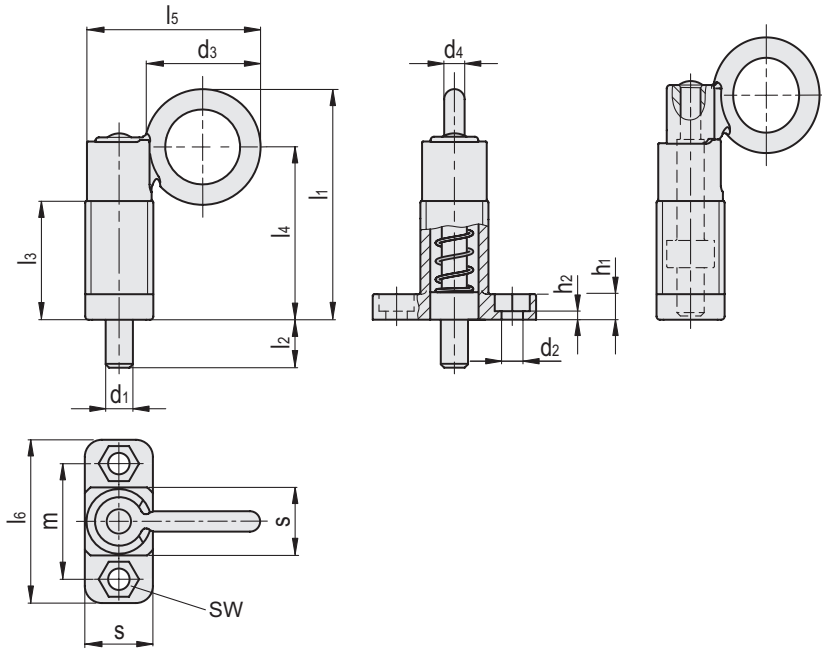

GN 722.5-C-ZB

Code	Description	d1 Plunger -0.05 -0.25 Hole +0.1 +0.3	d2 +0.3	d3	d4	h1	h2	l1	l2	l3	l4	l5	l6	s	sw	m	Spring preload [N]	Spring max load [N]	⚖️
GN.49503	GN 722.5-8-20-C-ZB	8	6.1	34	6	7.5	1.5	68	14	35	51	41.5	48	20	10	34	14	35	170
GN.49506	GN 722.5-10-20-C-ZB	10	6.1	34	6	7.5	1.5	68	14	35	51	41.5	48	20	10	34	14	35	172
GN.49509	GN 722.5-12-20-C-ZB	12	6.1	34	6	7.5	1.5	68	14	35	51	41.5	48	20	10	34	14	35	174
GN.49512	GN 722.5-14-20-C-ZB	14	6.1	34	6	7.5	1.5	68	14	35	51	41.5	48	20	10	34	14	35	181
GN.49515	GN 722.5-16-30-C-ZB	16	10.1	48	9	15	5	102	20	54	78	60	80	30	17	55	22	70	664
GN.49518	GN 722.5-20-30-C-ZB	20	10.1	48	9	15	5	102	20	54	78	60	80	30	17	55	22	70	670

GN 722.5-C-SW

Code	Description	d1 Plunger -0.05 -0.25 Hole +0.1 +0.3	d2 +0.3	d3	d4	h1	h2	l1	l2	l3	l4	l5	l6	s	sw	m	Spring preload [N]	Spring max load [N]	⚖️
GN.49502	GN 722.5-8-20-C-SW	8	6.1	34	6	7.5	1.5	68	14	35	51	41.5	48	20	10	34	14	35	170
GN.49505	GN 722.5-10-20-C-SW	10	6.1	34	6	7.5	1.5	68	14	35	51	41.5	48	20	10	34	14	35	172
GN.49508	GN 722.5-12-20-C-SW	12	6.1	34	6	7.5	1.5	68	14	35	51	41.5	48	20	10	34	14	35	174
GN.49511	GN 722.5-14-20-C-SW	14	6.1	34	6	7.5	1.5	68	14	35	51	41.5	48	20	10	34	14	35	181
GN.49514	GN 722.5-16-30-C-SW	16	10.1	48	9	15	5	102	20	54	78	60	80	30	17	55	22	70	664
GN.49517	GN 722.5-20-30-C-SW	20	10.1	48	9	15	5	102	20	54	78	60	80	30	17	55	22	70	670

Indexing and positioning elements

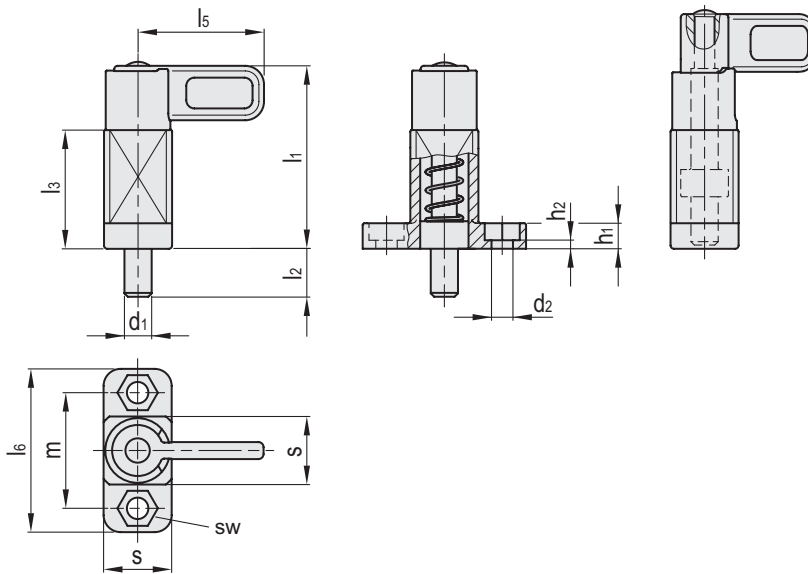

GN 722.5-E-ZB

Code	Description	d1 Plunger -0.05 -0.25 Hole +0.1 +0.3	d2 +0.3	h1	h2	l1	l2	l3	l5	l6	s	sw	m	Spring preload [N]	Spring max load [N]	⚖
GN.75863	GN 722.5-8-20-E-ZB	8	6.1	7.5	1.5	54	14	35	37	48	20	10	34	14	35	167
GN.75866	GN 722.5-10-20-E-ZB	10	6.1	7.5	1.5	54	14	35	37	48	20	10	34	14	35	170
GN.75869	GN 722.5-12-20-E-ZB	12	6.1	7.5	1.5	54	14	35	37	48	20	10	34	14	35	174
GN.75872	GN 722.5-14-20-E-ZB	14	6.1	7.5	1.5	54	14	35	37	48	20	10	34	14	35	178
GN.75875	GN 722.5-16-30-E-ZB	16	10.1	15	5	83	20	54	55	80	30	17	55	22	70	653
GN.75878	GN 722.5-20-30-E-ZB	20	10.1	15	5	83	20	54	55	80	30	17	55	22	70	671

GN 722.5-E-SW

Code	Description	d1 Plunger -0.05 -0.25 Hole +0.1 +0.3	d2 +0.3	h1	h2	l1	l2	l3	l5	l6	s	sw	m	Spring preload [N]	Spring max load [N]	⚖
GN.75862	GN 722.5-8-20-E-SW	8	6.1	7.5	1.5	54	14	35	37	48	20	10	34	14	35	167
GN.75865	GN 722.5-10-20-E-SW	10	6.1	7.5	1.5	54	14	35	37	48	20	10	34	14	35	170
GN.75868	GN 722.5-12-20-E-SW	12	6.1	7.5	1.5	54	14	35	37	48	20	10	34	14	35	174
GN.75871	GN 722.5-14-20-E-SW	14	6.1	7.5	1.5	54	14	35	37	48	20	10	34	14	35	178
GN.75874	GN 722.5-16-30-E-SW	16	10.1	15	5	83	20	54	55	80	30	17	55	22	70	653
GN.75877	GN 722.5-20-30-E-SW	20	10.1	15	5	83	20	54	55	80	30	17	55	22	70	671

